

Operating Instructions

Sequential Switcher
WJ-SQ308



Panasonic®

Before attempting to connect or operate this product, please read these instructions completely.

CONTENTS

PREFACE	1
FEATURES	1
PRECAUTIONS	2
MAJOR OPERATING CONTROLS AND THEIR FUNCTIONS	2
CAUTIONS	4
CONNECTIONS	5
SYSTEM APPLICATION	5
ADJUSTMENT	10
SPECIFICATIONS	11

For Canada

CAUTION:
 TO PREVENT ELECTRIC SHOCK DO NOT USE THIS (POLARIZED) PLUG WITH AN EXTENSION CORD, RECEPTACLE OR OTHER OUTLET UNLESS THE BLADES CAN BE FULLY INSERTED TO PREVENT BLADE EXPOSURE.

CAUTION:

Before attempting to connect or operate this product, please read the label on the bottom.



CAUTION

RISK OF ELECTRIC SHOCK
DO NOT OPEN



CAUTION:
 TO REDUCE THE RISK OF ELECTRIC SHOCK, DO NOT REMOVE COVER (OR BACK). NO USER SERVICEABLE PARTS INSIDE.
 REFER SERVICING TO QUALIFIED SERVICE PERSONNEL.



SA 1965

The lightning flash with arrowhead symbol, within an equilateral triangle, is intended to alert the user to the presence of uninsulated "dangerous voltage" within the product's enclosure that may be of sufficient magnitude to constitute a risk of electric shock to persons.



SA 1966

The exclamation point within an equilateral triangle is intended to alert the user to the presence of important operating and maintenance (servicing) instructions in the literature accompanying the appliance.

For U.S.A

Warning:
 This equipment generates and uses radio frequency energy and if not installed and used properly, i.e., in strict accordance with the instruction manual, may cause harmful interference to radio communications. It has been tested and found to comply with the limits for a Class A computing device pursuant to Subpart J of Part 15 of FCC Rules, which are designed to provide reasonable protection against such interference when operated in a commercial environment.

For CANADA

This digital apparatus does not exceed the Class A limits for radio noise emissions from digital apparatus set out in the Radio Interference Regulations of the Canadian Department of Communications.

The serial number of this product may be found on the bottom of the unit.
 You should note the serial number of this unit in the space provided and retain this book as a permanent record of your purchase to aid identification in the event of theft.

Model No. _____ WJ-SQ308 _____

Serial No. _____

WARNING:
 TO PREVENT FIRE OR SHOCK HAZARD, DO NOT EXPOSE THIS APPLIANCE TO RAIN OR MOISTURE.

PREFACE

Panasonic sequential switchers are excellent accessories for multi-camera security systems. The WJ-SQ308 is a 8-input switcher with alarm.

This sequential switcher has two video outputs : alarm/sequential and alarm/spot monitor.

The alarm/sequential output displays each camera in sequence is being displayed. The alarm/spot monitor output permits manual selection of any camera for display on a second monitor ; when not used, this output automatically becomes sequential. Any camera switched to the "Spot monitor" position is still included in the switching sequence. A bypass switch allows any camera to be bypassed from the switching sequence.

This sequential switcher also has vertical interval switching for glitch free switching among synchronized cameras.

The length of time each camera is displayed during the sequence is manually adjustable from 1 to 30 seconds.

FEATURES

1. Two video outputs : alarm/sequential and alarm/spot .
2. Alarm/sequential output displays each camera in sequence.
3. Front panel indicators show which camera is being displayed.
4. Alarm/spot output for manual selection of any camera for display on a second monitor.
5. Alarm/spot output : when not used, automatically becomes sequential.
6. Any camera switched to the spot monitor position is still included in the switching sequence.
7. Bypass switch skips any camera from sequence.
8. Vertical interval switching for glitch free switching among synchronized cameras.
9. Switching interval manually adjustable from 1 to 30 seconds.
10. Switching interval can be externally controlled by Time Lapse VTR or by another sequential switcher.
11. Loop-through video connectors with automatic termination are provided.
12. ALARM MODE
 - (1) Inputs for 8 sensors : door switch, window switch, mat switch, etc.
 - (2) When a sensor is activated, sequential output is automatically switched to that camera.
 - (3) If two or more sensors are activated, the switcher automatically switches between those cameras that are in the alarm mode.
 - (4) Front panel LED indicates alarm condition.
 - (5) Alarm can be manually reset by switch on front panel.
 - (6) Automatic reset of alarm after 1 to 5 minutes interval (internally adjustable using VR2). Refer to the ADJUSTMENT on page 10.
 - (7) Ideal mate for Panasonic Time Lapse VTR.
 - (8) Switcher alarm output activates Time Lapse VTR alarm mode : VTR changes its recording speed for greater detail during alarm period.
 - (9) Switcher can reset VTR alarm mode, or VTR can reset switcher alarm mode.

PRECAUTIONS

- Do not attempt to disassemble the instrument. In order to prevent electric shock, do not remove screws or covers. There are no user-serviceable parts inside. Do refer all servicing to qualified service personnel.
- Do not abuse the instrument. Avoid striking, shaking, etc. It could be damaged by improper handling or storage. Do handle the instrument with care.
- Do not use strong or abrasive detergents when cleaning the instrument body. Do use a dry cloth to clean the instrument when dirty. In case the dirt is hard to remove, use mild detergent and wipe gently.
- Do not expose the instrument to water or moisture, and do not operate in wet area. Do take immediate action if ever the instrument does become wet. Disconnect the AC adaptor from AC outlet and refer servicing to qualified service personnel.

Moisture can damage the instrument and also create the danger of electric shock.

- Be sure to disconnect the AC Adaptor from the AC outlet while this sequential switcher is not used.
- All necessary procedures with regard to the installation of this product should be made by qualified service personnel or system installers.
- Do not use the instrument in an extreme environment where high temperature or high humidity exist. Use the instrument under conditions where temperatures are within 14°F - 122°F (-10°C - +50°C), and humidity is below 95%.

MAJOR OPERATING CONTROLS AND THEIR FUNCTIONS

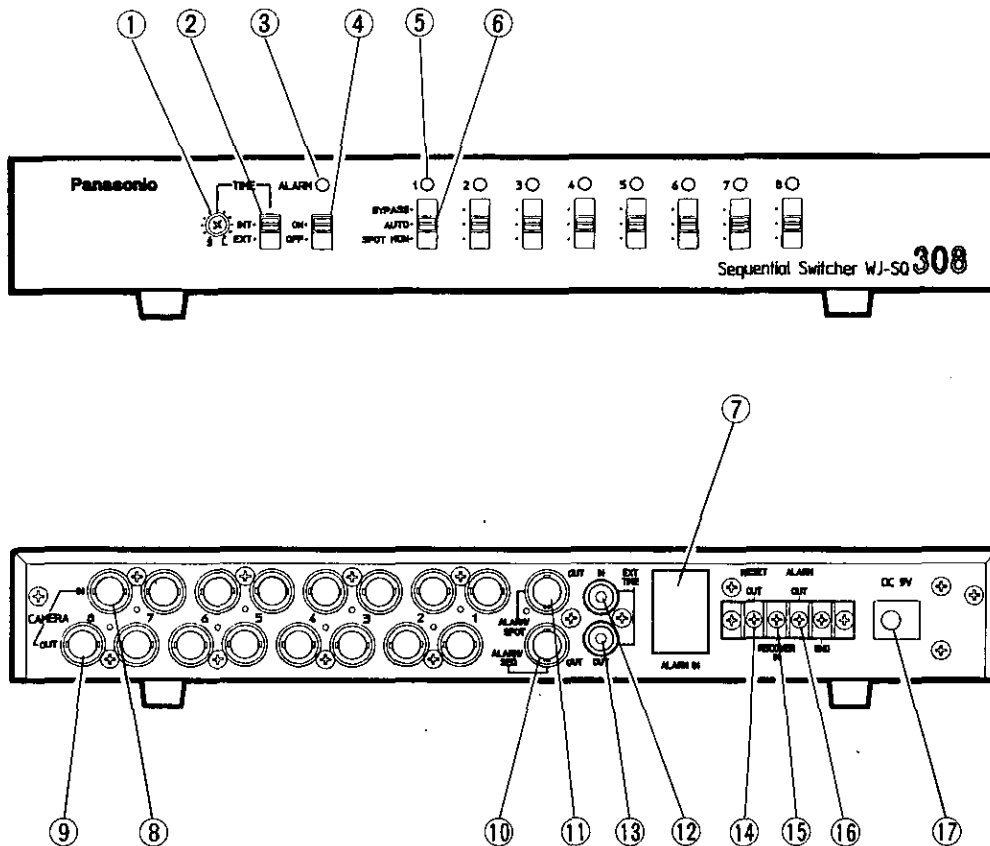

1. Time Control (S/L)

The sequential switcher's timing can be continuously changed from approx. 1 to 30 seconds by turning this control.

2. Time Internal / External Selection Switch (INT/EXT)

This switch is used to select the timing control signal source.

INT: Select this position when the sequential switcher's timing is controlled using the Time Control(1).

EXT: Select this position when the sequential switcher's timing is controlled by an external timing pulse.

If trigger signals from a Time Lapse VTR are connected to the External Timing Input Connector (12) when using it in combination with this sequential switcher, the sequential switcher will be controlled by the trigger signals from that Time Lapse VTR.

3. Alarm Indicator

When the Alarm On/Off Selection Switch is set to the ON position, this indicator lights.

When the alarm signal is supplied to the Alarm Signal Input Connector in the Alarm On mode, this indicator blinks.

4. Alarm On/Off Selection Switch (ON/OFF)

ON: Select this position when an alarm input into the Alarm Input Connector will automatically operate the alarm function. After a predetermining interval of alarm operation, the normal sequence operation is resumed.

OFF: Select this position when the alarm function is suspended so that no alarm operation will take place even if an alarm input is received.

In this case, a reset signal will be output from the Reset Output Terminal (14) of the Alarm Input Connector (7) on the back panel.

5. Sequence Output Indicators (1/2/3/4/5/6/7/8)

A lit lamp indicates that the signals of the corresponding camera are available at the Camera Output Connector.

6. 3-position Selection Switches (BYPASS/AUTO/SPOT MON)

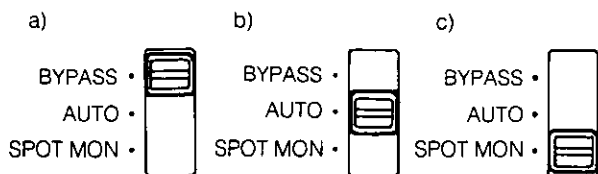

a) BYPASS mode

When this switch is set to the BYPASS position, the camera signals in this position will be skipped regardless of the presence of a video signals while the other camera signals will be fed out in sequence. In other words, the signals of that camera will not be fed out of Alarm Sequential Output Connector(10). This function may be very convenient in cases where monitoring requirements vary from time to time.

b) AUTO mode

When the switch is set to this position, the signals of the camera will be automatically in sequence regardless of the presence of a video signal from that source.

c) SPOT mode

When the switch is set to this position, the signals of the camera in that position will be output from of the Alarm Spot Output Connector(11) so that this camera signal can be selectively monitored. During this time, sequence operation goes on and sequence outputs are fed out from the Alarm Sequential Output Connector(10). If two or more cameras are set in this mode, the signal of the lower numbered camera in this position will be used as output signal.

7. Alarm Input Connector (ALARM IN)

The alarm sensor closure switches are connected to these terminals.

8. Camera Input Connectors (CAMERA IN)

These are used to connect the video output signals from cameras. When connected, the signals will be terminated at 75 ohms.

9. Camera Output Connectors (CAMERA OUT)

The video input signals connected to the Camera Input Connectors (8) are looped through to these connectors.

10. Alarm Sequential Output Connector (ALARM/SEQ OUT)

This is a sequential switcher output connector which always produces sequence outputs except during an alarm connection when the output switches to the alarmed camera position.

11. Alarm Spot Output Connector (ALARM/SPOT OUT)

This is a manual video switcher output connector, which normally produces the same sequence operation output signals as the alarm sequential output. However, if a camera selection switch is in the SPOT MON position, that camera will be output from this connector.

12. External Timing Input Connector (EXT TIME IN)

This input connectors for sequence operation with external timing pulses. Connect the trigger signals from a Panasonic Time Lapse VTR to this connector.

13. External Timing Output Connector (EXT TIME OUT)

This connector outputs timing pulse signals which are synchronized with the sequence operation. As shown in the system application examples, two or more switchers may be used together in either a synchronized or asynchronous manner. When synchronized, the External Timing Output Connector of one switcher (the Master unit) is connected to the External Timing Input Connector the second unit (the Slave unit). The Slave unit's TIME INT/EXT SELECTION SWITCH should be set to the EXT position. The Master unit's TIME INT/EXT SELECTION SWITCH may be to either INT or EXT, depending on whether a Time Lapse VTR used.

14. Reset Output Terminal (RESET OUT)

This terminal is connected to the Alarm On/Off Selection Switch (4). When setting the Alarm On/Off Selection Switch (4) to the OFF position and connecting the reset terminal of the Time Lapse VTR to this terminal, the alarm function will stop.

15. Recover Input Terminal (RECOVER IN)

When this is connected to the recover output terminal on the Time Lapse VTR, this switcher will stay in the alarm mode as long as the Time Lapse VTR stays in its alarm mode. After that, normal sequence operation is resumed.

Note: Time Lapse VTR alarm mode must be set for a minimum of 60 seconds for this feature to function.

16. Alarm Output Terminal (ALARM OUT)

If this terminal is connected to the alarm input terminal on the Time Lapse VTR, the Time Lapse VTR will be automatically switched over from long-time recording to normal-time recording at the same time as this switcher starts alarm operation. This terminal is an open collector output, to which loads of up to 30V 100mA can be connected. Thus it may be used for controlling an alarm device by using a relay, for example.

If this terminal is connected to the detection connector on the time-date generator WJ-810, the cumulative number of alarms and the time of the last alarm are indicated.

17. Adaptor Connector (DC 9V)

Connect an AC Adaptor (supplied) to this connector.

CAUTIONS

1. The External Timing Output Connector(13) and Alarm Output Terminal(16) are open collector outputs. They will not operate unless loads are connected to them externally and DC power (not to exceed (Max.30V 100mA) is supplied externally.
2. When the Alarm On/Off Selection Switch (4) is set to the OFF position, the alarm mode will not operate even if an alarm input is received. When the sequential switcher is connected to the Time Lapse VTR, the alarm will not operate if either of them has its alarm selector in the Alarm OFF (Reset) position.
3. If the Alarm Spot Output Connector (11) is used for monitoring and if any one of the 3-position Selection Switches (6) is in the SPOT MON position, only the signal of the camera which is in the SPOT MON mode will be output, even during an alarm condition. If none of the 3-position Selection Switches are in the Spot Mon position during an alarm condition, the Alarm Spot Output Connector will output the alarmed camera position.
4. Alarm Time Control is preset for 60 second duration at the factory.
However, this duration can be varied within the range of 1 to 5 minutes.It is varied by turning the internal Alarm Time Control VR2.

CONNECTIONS

SYSTEM APPLICATION

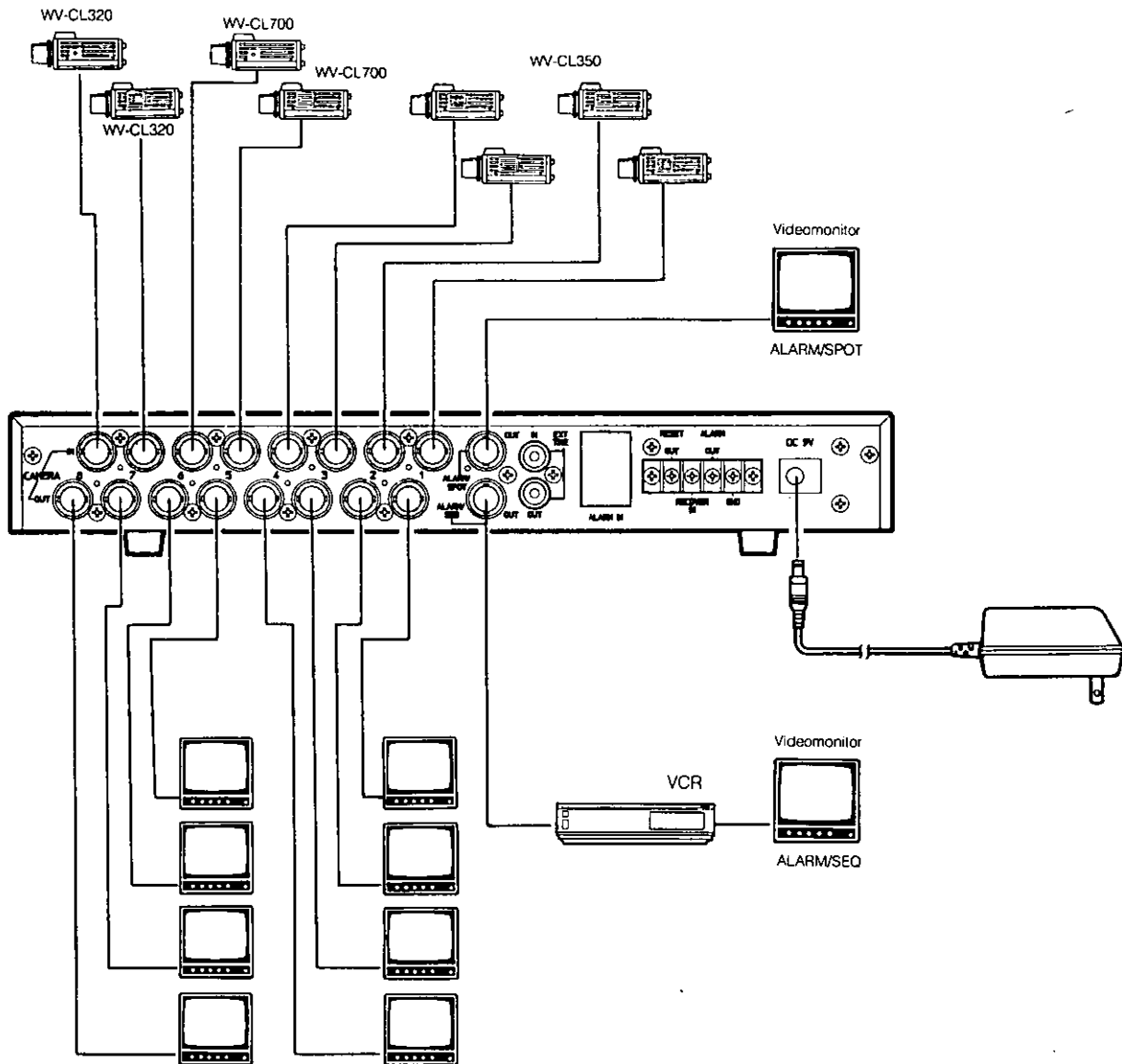

- Connect the sensor switches and the Time Lapse VTR with the proper cables. The sensor should have an open-collector output or non-voltage contact.

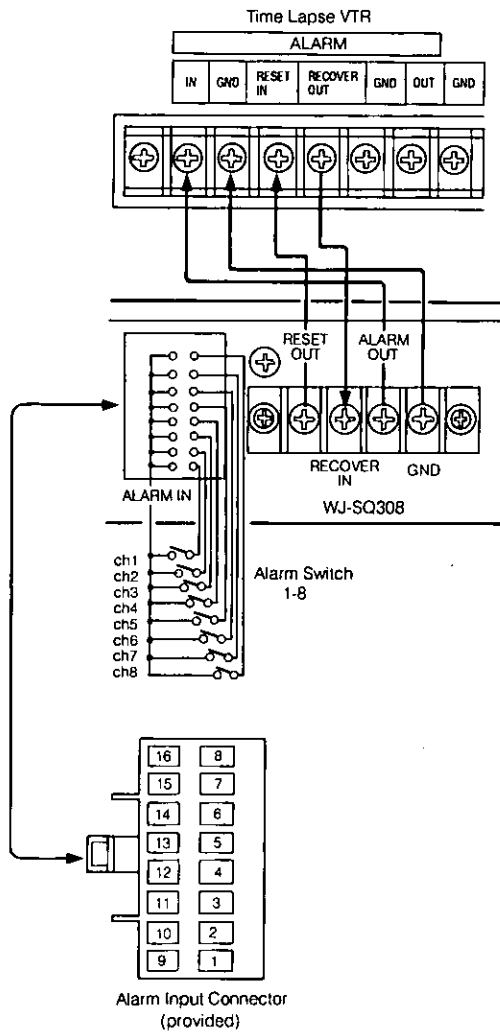

Alarm Input Connector (provided)

Pin No.	Signals	Wire Color
1	ch1 Input	Brown
2	ch2 Input	Red
3	ch3 Input	Orange
4	ch4 Input	Yellow
5	ch5 Input	Green
6	ch6 Input	Blue
7	ch7 Input	Purple
8	ch8 Input	Grey
9	ch1 earth	Black
10	ch2 earth	Black
11	ch3 earth	Black
12	ch4 earth	Black
13	ch5 earth	Black
14	ch6 earth	Black
15	ch7 earth	Black
16	ch8 earth	Black

Note: Be sure to insulate the wire(s) which is (are) not connected.

- The capacity of the Alarm Output Connector is 30V DC maximum, 100mA or less

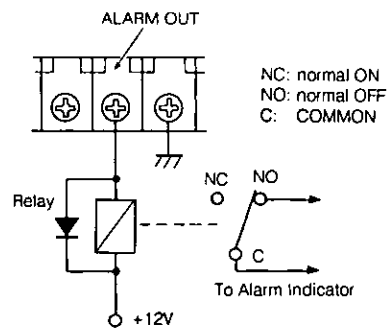

1. Single Connection

A. Without VCR

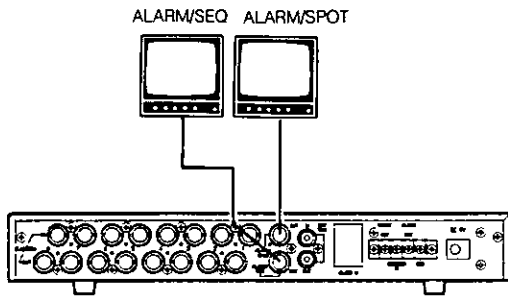

B. With VCR

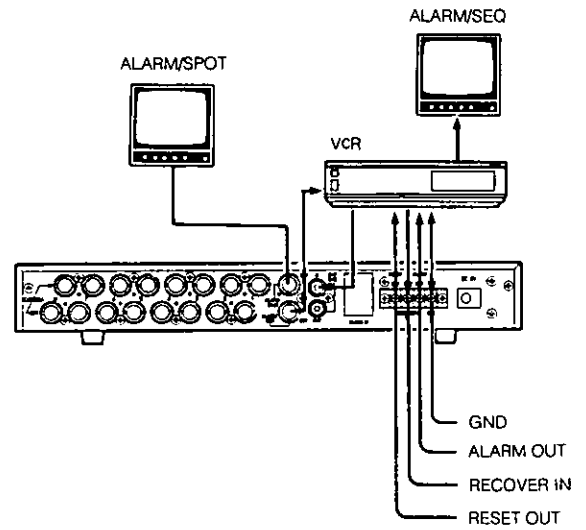

2. Parallel Connection

C. Without VCR

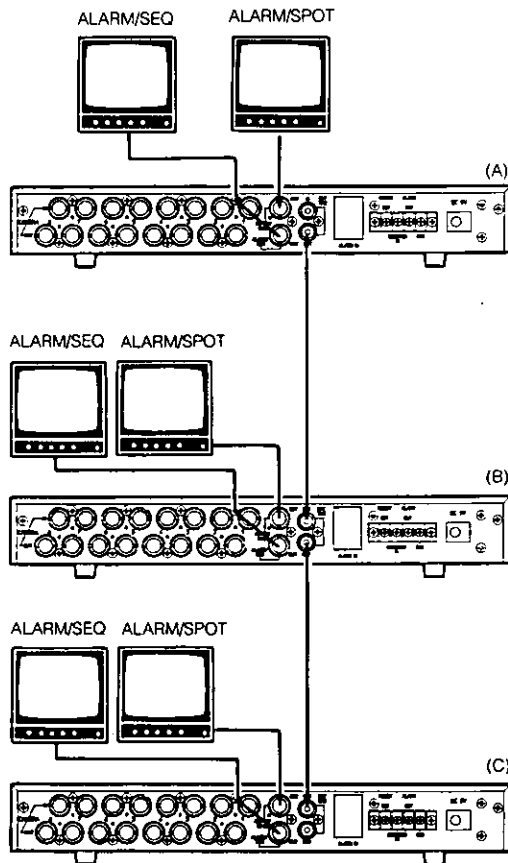

D. With VCR

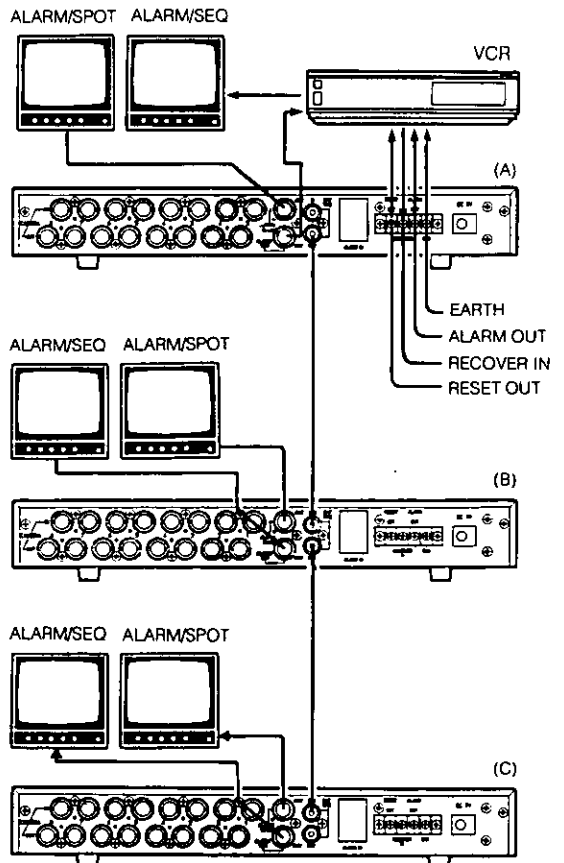

Sequential Switching Time

Table 1

Signal Output Condition	Without VCR	With VCR
Sequential Switching Time	The sequential switcher's timing can be adjusted using the Time Control (1) when the Time Internal/External Selection Switch (2) is set to the INT position.	The sequential switcher's timing can be adjusted by the timing pulse from VCR when the Time Internal/External Selection Switch (2) is set to the EXT position. Note: When the VCR is turned off, the sequence is stopped.
Normal Sequence mode 1. Alarm/Spot Output Connector 2. Alarm/Sequential Output Connector	Signal can be output sequentially by the switching time set with the Time Control (1).	Signal can be output with the sequential timing by the timing pulse from VTR.
Spot mode 1. Alarm/Spot Output Connector 2. Alarm/Sequential Output Connector	1. The signal is output with Spot switching. 2. The signal is output sequentially.	1. The signal is output with Spot switching. 2. The signal is output sequentially.
Alarm mode (1 input) 1. Alarm/Spot Output Connector 2. Alarm/Sequential Output Connector	1. The alarmed video signal is output from the Alarm Spot Output Connector (11). (The spot operation is available for 1-ch - 8-ch) 2. The alarmed video signal is output from the Alarm Sequential Output Connector (10).	1. The alarmed video signal is output from the Alarm Spot Output Connector (11). (The spot operation is available for 1-ch - 8-ch) 2. The alarmed video signal is output from the Alarm Sequential Output Connector (10).
Alarm mode (multiple input) 1. Alarm/Spot Output Connector 2. Alarm/Sequential Output Connector	1. The alarmed video signals are output sequentially from the Alarm/Spot Output Connector with the timing set by the Time Control (1). (The spot or bypass operation is available for 1-ch - 8-ch) 2. The alarmed video signals are output sequentially from the Alarm/Seq Output Connector with the timing set by the Time Control (1). (The bypass Operation is available for 1-ch - 8-ch)	1. The alarmed video signals are output sequentially from the Alarm/Spot Output Connector with the timing set by the timing pulse from VCR. (The spot or bypass operation is available for 1-ch - 8-ch) 2. The alarmed video signals are output sequentially from the Alarm/Seq Output Connector with the timing pulse from VCR. (The bypass Operation is available for 1-ch - 8-ch)

Note: The switching interval of VCR and camera should be 0.3 seconds or more.

Table 2

Signal Output Condition	Without VCR	With VCR
Sequential switching Time	<p>C-A: The sequential switcher's timing can be adjusted using the Time Control (1) when the Internal/External Selection Switch (2) is set to the INT position.</p> <p>C-B/C: The signals are synchronized with C-A when the Time Internal/External Selection Switch (2) on WJ-SQ308s (C-B and C-C) are set to the EXT position. Set Internal/External (C-A) Selection switch to INT position.</p>	<p>All of the WJ-SQ308 is can be sequenced with the timing pulse from VCR:</p> <p>Note: Be sure to set the Time Internal/External Selection Switch (2) to the EXT position</p>
<p>Normal Sequence mode</p> <p>1. Alarm/Spot Output Connector</p> <p>2. Alarm/Sequential Output Connector</p>	<p>The signal from all of the WJ-SQ308s are output sequentially with the switching time from the C-A Unit.</p>	<p>All of the WJ-SQ308s are sequenced with the timing pulse from the VCR.</p>
<p>Spot mode</p> <p>1. Alarm/Spot Output Connector</p> <p>2. Alarm/Sequential Output Connector</p>	<p>1. The WJ-SQ308 in the spot mode supplies the selected video signal to the Alarm Spot Output Connector (11). All Other WJ-SQ308s go to sequencing with the timing set by the WJ-SQ308 (C-A).</p> <p>2. The signal from all of the WJ-SQ308S are output sequentially with the switching time set by the WJ-SQ308 (C-A).</p>	<p>1. The WJ-SQ308 in the spot mode supplies the selected video signal to the Alarm Spot Output Connector (11). All other WJ-SQ308s go to sequencing with the switching time set by the timing pulse from VCR.</p> <p>2. The signal from all of the WJ-SQ308s are switched with the switching time by the timing pulse from VCR</p>
<p>Alarm mode (1 input)</p> <p>1. Alarm/Spot Output Connector</p> <p>2. Alarm/Sequence Output Connector</p>	<p>1. The alarmed video signal is output from the Alarm Spot Output Connector (11). Other WJ-SQ308s go to sequence. (The spot operation is available for 1-ch - 8-ch)</p> <p>2. The alarmed video signal is output from the Alarm Spot Output connector (11). All Other WJ-SQ308s go on the sequence.</p>	<p>1. The WJ-SQ308 (D) supplied with the alarm signal is switched to the alarm picture. All other WJ-SQ308s go to sequence. (The spot operation is available for 1-ch - 8-ch)</p> <p>2. The WJ-SQ308 (D-B) supplied with the alarm signal is switched to the alarm picture. All Other WJ-SQ308s go to sequencing with the switching time set by the timing pulse from VCR.</p>
<p>Alarm mode (multiple input) In case of alarm input to the (C-B or D-B)</p> <p>1. Alarm/Spot Output Connector</p> <p>2. Alarm/Sequential Output Connector</p>	<p>1. The alarm timing of the WJ-SQ308 (C-C), supplied the alarm input signal, is sequenced with the timing of WJ-SQ308 All Other WJ-SQ308s go for sequence. (The spot or bypass operation is available for 1-ch - 8-ch)</p> <p>2. The alarm timing of the WJ-SQ308 (C-B), supplied the alarm input signal, is sequenced with the timing of Master WJ-SQ308 All other WJ-SQ308s go to sequence. (The bypass operation is available for 1-ch - 8-ch)</p>	<p>1. The alarm timing of, the WJ-SQ308 (D-B) supplied the alarm input signal, is sequenced with the timing pulse from VCR. All Other WJ-SQ308s go to sequence. (The spot or bypass operation is available for 1-ch - 8-ch)</p> <p>2. The alarm timing of, the WJ-SQ308 (D-B) supplied with the alarm input signal, is sequenced with the timing pulse from VCR. All Other WJ-SQ308s go to sequence. (The bypass operation is available for 1-ch - 8-ch)</p>

Notes:

The switching interval of VCR and Camera should be 0.3 seconds or more.

Each screen of video monitors are not same with the camera screen.

A Time Lapes VTR may be connected to each WJ-SQ308.

ADJUSTMENT

Alarm Timing Adjustment

The alarm timing interval is preset to approx. 1 minute. And by turning the VR2, the alarm timing interval can be set from 1 to 5 minutes.

1. Connect the Alarm Input Connector (7) with the Ground Terminal (GND). The alarm operation can be obtained and the Alarm Indicator (3) blinks.
2. Adjust the alarm timing interval by turning the VR2 while observing the Alarm Indicator (3) status.

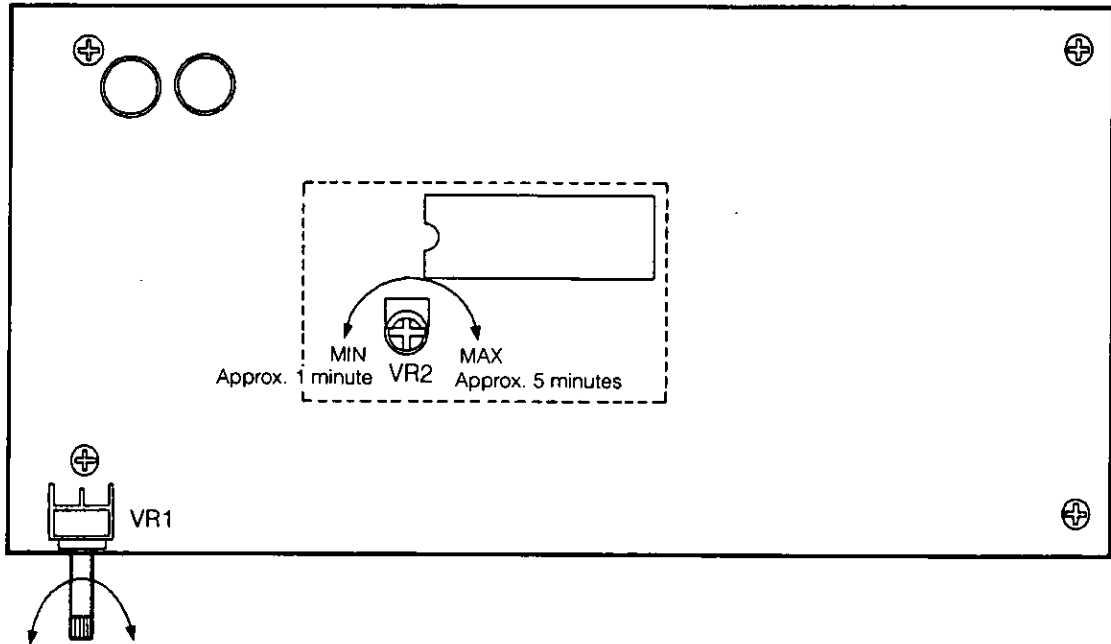

Note : In case of using this switcher with the Time Lapse VTR, be sure to adjust the alarm timing interval of this switcher so that it is shorter than the Time Lapse VTR.

SPECIFICATIONS

Camera Inputs :	1.0 Vp-p Composite / 75 ohms (BNC) x 8 with Loop-through Outputs
Camera Outputs :	Alarm / Sequence Out : 1.0Vp-p Composite / 75 ohms (BNC) x 1
	Alarm / Spot Out : 1.0Vp-p Composite / 75 ohms (BNC) x 1
Frequency Response :	4 MHz \pm 1 dB
Gain :	Unity
Switching Interval :	Approx. 1 to 30 sec.
EXT. Time Input :	5.0 Vp-p Pulse input Timing Pulse from Time-lapse VCR, or other Sequential Switcher's External Timing Output (WJ-SQ308 or WJ-527)
EXT. Time Output :	Open Collector (Max. DC30V, Max. 100 mA), Looping through of EXT. Time In or Internal Timing Pulse (Normally connected to VCR or to other Sequential Switcher's External Timing Input : WJ-SQ308 or WJ-527
Alarm Input :	Open Collector, 8 Inputs (16 Pin)
Operating Time of Alarm :	Factory Set : Approx. 1 min. (Internally Adjustable 1 to 5 min.)
Alarm Output :	Open Collector (Max. DC 30V, Max. 100 mA)
Reset Output :	5.0V DC
Recover Input :	Open Collector
Power Source :	DC 9V with provided AC Adaptor
Ambient Operating Temperature :	+14°F to +122°F (-10°C to +50°C)
Dimensions (W X H X D) :	13" x 1-3/4" x 7-7/8" (330 x 44 x 200 mm)
Weights :	4.2lbs (1.9Kg)

Dimensions and weights are approximately.
Specifications are subject to change without notice.

ACCESSORIES

- AC Adaptor1 pc.
- Alarm Input Connector1 pc.

Panasonic

Broadcast & Television Systems Company

Division of Matsushita Electric Corporation of America

CLOSED CIRCUIT VIDEO EQUIPMENT DIVISION

Executive Office: One Panasonic Way, Secaucus, New Jersey 07094

Regional Offices:

Northeast: 43 Hartz Way, Secaucus, NJ 07094 (201) 348-7303

Southeast: 1854 Shackelford Court, Suite 115, Norcross, GA 30003 (404) 717-6835

Midwest: 1707 North Randall Road, Elgin, IL 60123 (708) 468-5200

Southwest: 4500 Amon Carter Blvd., Ft. Worth, TX 76155 (817) 685-1117

Western: 6550 Katella Ave., Cypress, CA 90630 (714) 373-7265

MATSUSHITA ELECTRIC OF CANADA LIMITED

5770 Ambler Drive, Mississauga, Ontario, L4W 2T3 Canada (416)624-5010

PANASONIC SALES COMPANY

DIVISION OF MATSUSHITA ELECTRIC OF PUERTO RICO, INC.

San Gabriel Industrial Park, 65th Infantry, Ave. KM. 9.5 Carolina, Puerto Rico 00630 (809)750-4300